



Cutting Edge Cleat Installation Instructions

STEP 1:

Position the appropriate template on the mounting surface. (Templates are provided on back)

STEP 2:

Mark the four holes using a 1/8" drill bit or other marking device. Using the template helps keep the holes in line with each other and spaced appropriately. Otherwise use the distances indicated in the chart below.

STEP 3:

Remove the template and drill holes to the sizes indicated in the chart below. Be sure to drill holes perpendicular to the mounting surface.

STEP 4:

Apply sealant around the base of the cleat.

STEP 5:

Insert the cleat in to the cutout and bolt in place using the provided washers and nylon lock nuts.

STEP 6:

Tighten the nylon lock nuts to 20 ft-lb (27Nm) of torque. Install with a socket wrench.

Installation with a power tool will void the GEM warranty.

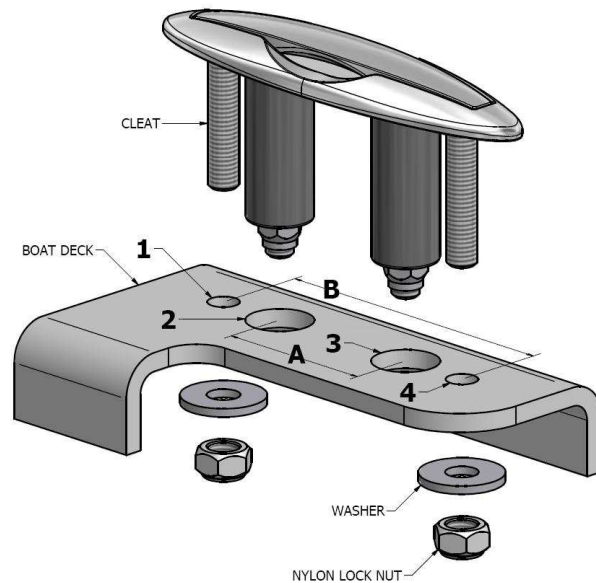

Item #	Style	Size	Distance A	Distance B	Hole 1 & 4 Size	Hole 2 & 3 Size
68502	Sleek	6"	2.25" [57mm]	4.25" [108mm]	1/2" [13mm]	1" [25mm]
68503	Widebase	6"	2.25" [57mm]	4.25" [108mm]	1/2" [13mm]	1" [25mm]
68504	Sleek	8"	2.8" [71mm]	5.3" [135mm]	5/8" [16mm]	1-1/8" [28mm]
68505	Widebase	8"	2.8" [71mm]	5.3" [135mm]	5/8" [16mm]	1-1/8" [28mm]

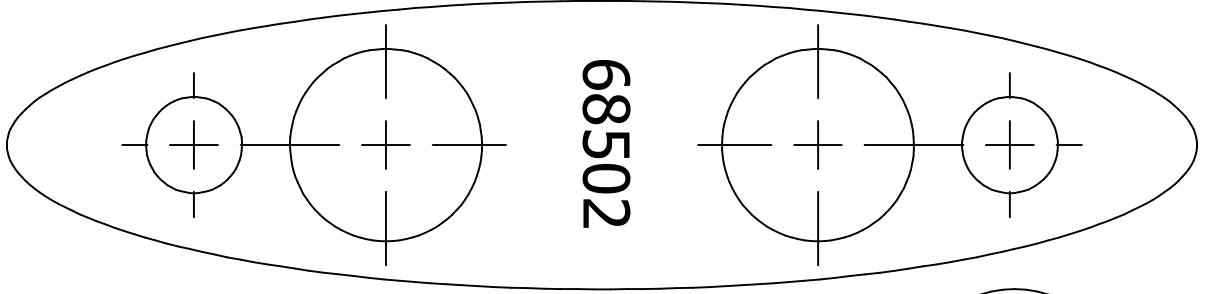

68502

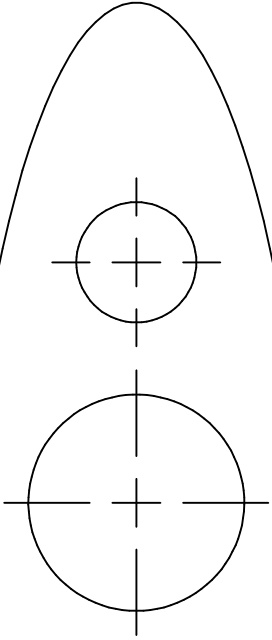

68504

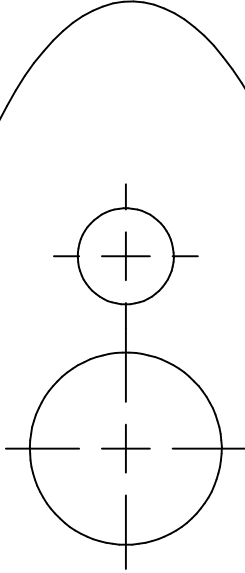

68503

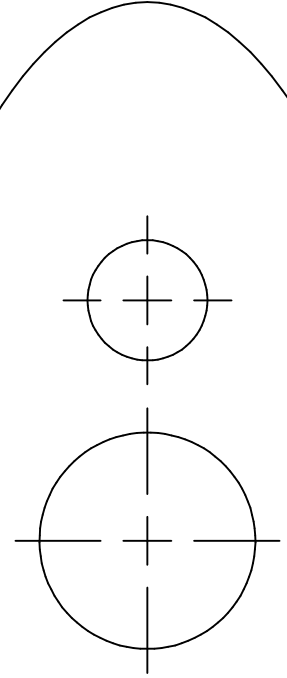

68505

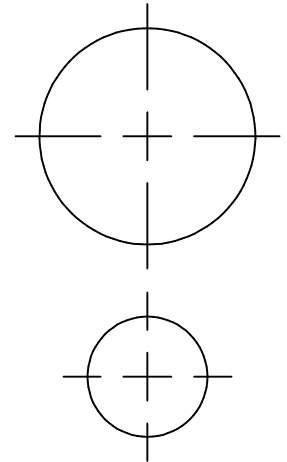
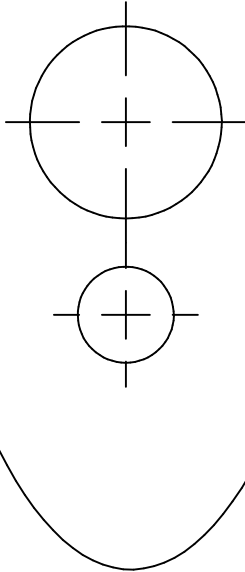
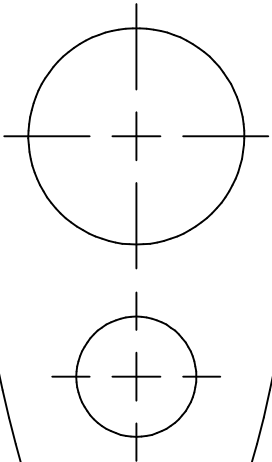

*PLEASE NOTE: Some printers may distort these templates, please verify dimensions with the table on page 1