

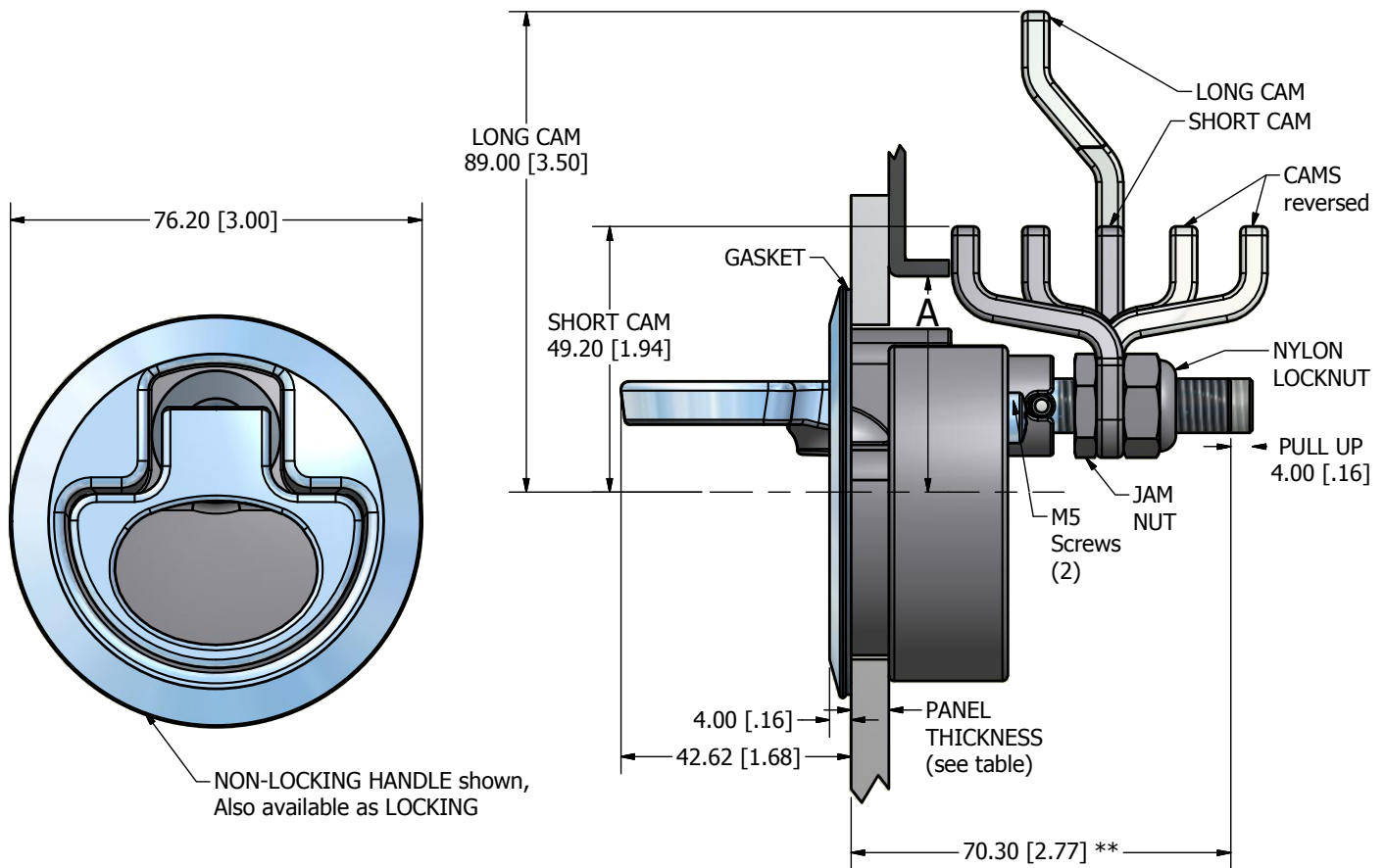

2.5" BEVELED EDGE COMPRESSION LATCHES

- 316 Stainless Steel*
- Latch available in both Locking and Non-Locking
- Superior GEMLUX Finish
- Single, 2.5" Round Hole Installation



Series	Hole ϕ	Panel Thickness X	Grip Range				Part Number				A		
			Cam Forward		Cam Reversed		Non-Locking		Locking				
			MIN	MAX	MIN	MAX	Short Cam	Long Cam	Short Cam	Long Cam	Short Cam	Long Cam	
5030	63 [2.5]	2 [.075] to 12 [.475]	4030-1111 [X + 20.5]	35[1.38]	74[2.91]	88[3.47]	5030-1111	5030-1114	5030-1211	5030-1214	40+1.5 [1.57+.06]	75+1.5 [2.95+.06]	
			4030-1114 [X + 14.5]	34[1.34]	48[1.89]	60[2.36]	75[2.95]	5030-1112	5030-1115	5030-1212			5030-1215
				47[1.85]	61[2.40]	-	-	5030-1113	5030-1116	5030-1213			5030-1216
		12 [.475] to 22.5 [.885]	4030-1121 [X + 10.5]	35[1.38]	74[2.91]	88[3.47]	5030-1121	5030-1124	5030-1221	5030-1224			
			4030-1124 [X + 4.5]	34[1.34]	48[1.89]	60[2.36]	75[2.95]	5030-1122	5030-1125	5030-1222			5030-1225
				47[1.85]	61[2.40]	-	-	5030-1123	5030-1126	5030-1223			5030-1226

All dimensions in millimeters [inches]

*Some components made of 304 stainless steel and nylon

**Note - For shaft length = 3.3in, change 2nd digit in part to "1"

For shaft length = 4.5in, change 2nd digit in part to "2"